



Selectable Room Intercom

SYSTEM USER'S GUIDE

IntercomsOnline.com

8161 Highway 100, #194

Nashville, TN 37221

www.IntercomsOnline.com

888-298-9489

TABLE OF CONTENTS

A. Introduction	3
B. System Components Overview	3
C. User Interface Overview	4
1. How to Navigate the User Interface:	5
2. Pop-up Style Message Screens:	6
D. System Operation.....	7
1. How to Page or “ALL” Call	7
2. How to Reply to a Page.....	7
3. How to Selectively Call a Location	8
4. How to Reply to a Selective Call	9
5. How to Mute a Unit.....	9
6. How to place a Unit in Monitor Mode.....	10
7. How to Temporarily Disable a Patio Unit	11
8. How to initiate a Door Call	13
9. How to initiate a Door Release	14
10. How to select a Door Chime Tone	15
E. System Personalization	17
1. Choosing Unit Names	17
2. Modifying Hands-Free Reply Time.....	19
3. Room Options (Local Settings).....	20
4. Door Options (Local Settings).....	22
5. Patio Options (Local Settings)	24

A. Introduction

The Selectable Room Intercom System (see **Figure 1**) is an advanced Cat 5 based intercom system consisting of 2-gang Room Units, Patio Units and Door Units connected with a single Cat 5 cable each to an Intercom Distribution Module in a structured wiring enclosure. The Room Units contain an intuitive graphical user interface in the form of a liquid crystal display, similar to today's cell phones. Communication may occur in a broadcast fashion if desired, or to specific units as selected on the LCD.

B. System Components Overview

System Components

The following components (in addition to a suitable power supply) are typically utilized to make up the Selectable Room Intercom System:

- **Distribution Module:** This module is typically installed in the On-Q enclosure and is considered the System Command, Communication and Power Router of the system. All Room Units, Patio Units and Door Units are connected directly to the Module via "home run" style single Cat 5e cabling. The Intercom Module also supplies power to the entire SCI System. Up to eight units of any combination are supported by each module and modules may be cascaded three times, for a total system support of up to 32 units.
- **Room Unit:** Through the LCD display, this unit provides both basic intercom communication functions such as talk, talk to door (if Door Unit is installed), monitor, mute, and advanced functions such as dynamic sorting of users or monitoring multiple rooms at the same time. Up to 8 Room Units can be installed per Intercom Distribution Module, and up to 32 per system.
- **Patio Unit:** This unit also provides similar basic Room Unit functionality in a weather resistant wall mounted package for your patio. For security reasons, it does not support the door release function. There are no specific limits as to the mix of Room Units and Patio Units up to the physical limitation of 8 per module and 32 per system.
- **Door Unit:** This unit allows a visitor to the home to press the door chime button on the unit to notify the occupants of their presence. The occupants can then initiate a two-way communication with the visitor, and even open the door (requires electronic door release device, not included). Up to 20 different door tones can be selected as the door tone that is played when the door chime button is pressed. There are no limits to the mix of Room, Patio and Door Units up to the physical limit of 8 per Distribution Module and 32 per system.

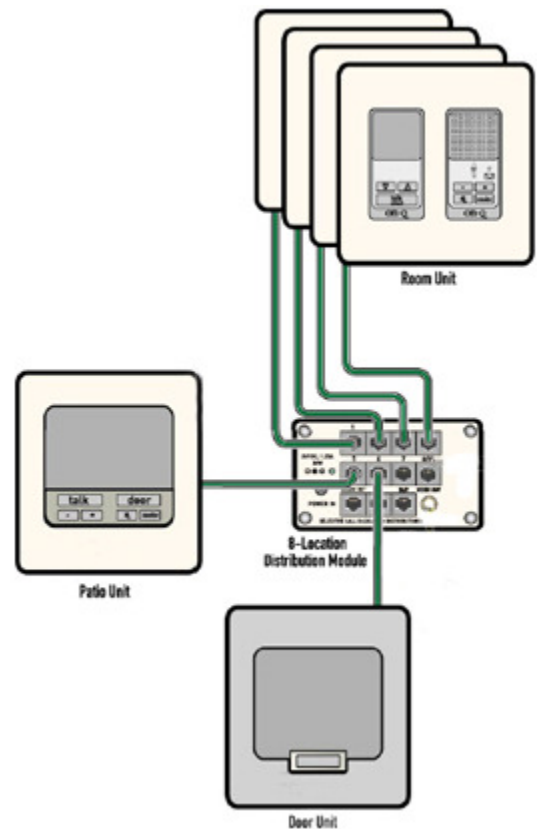

C. User Interface Overview

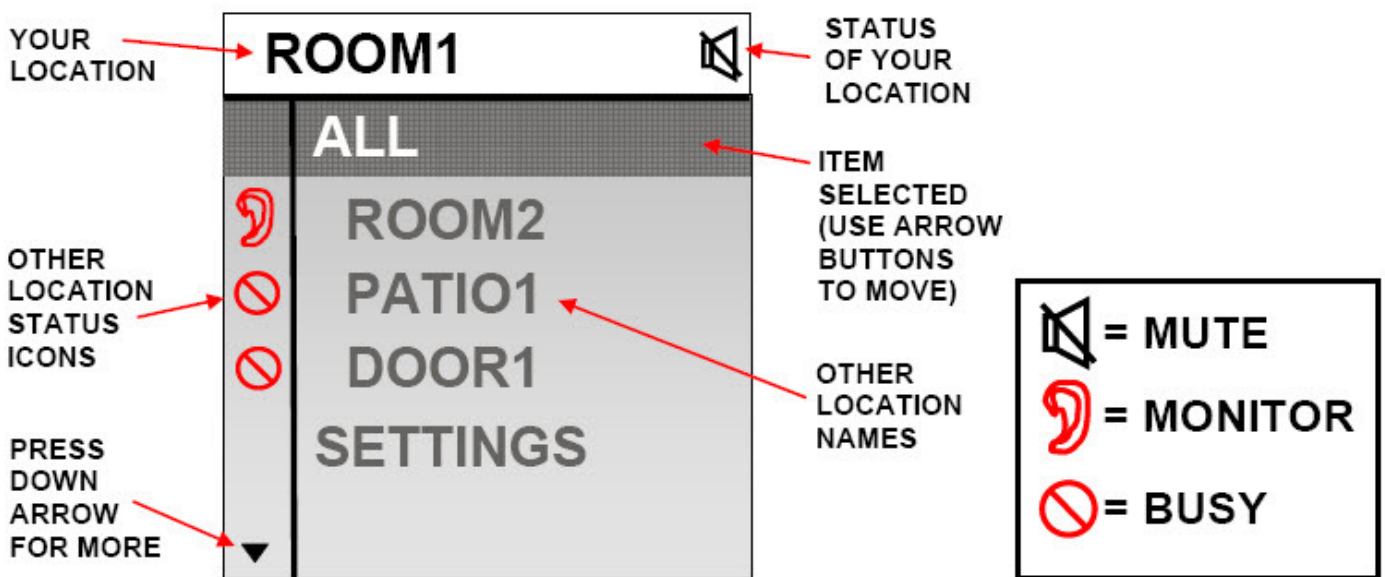
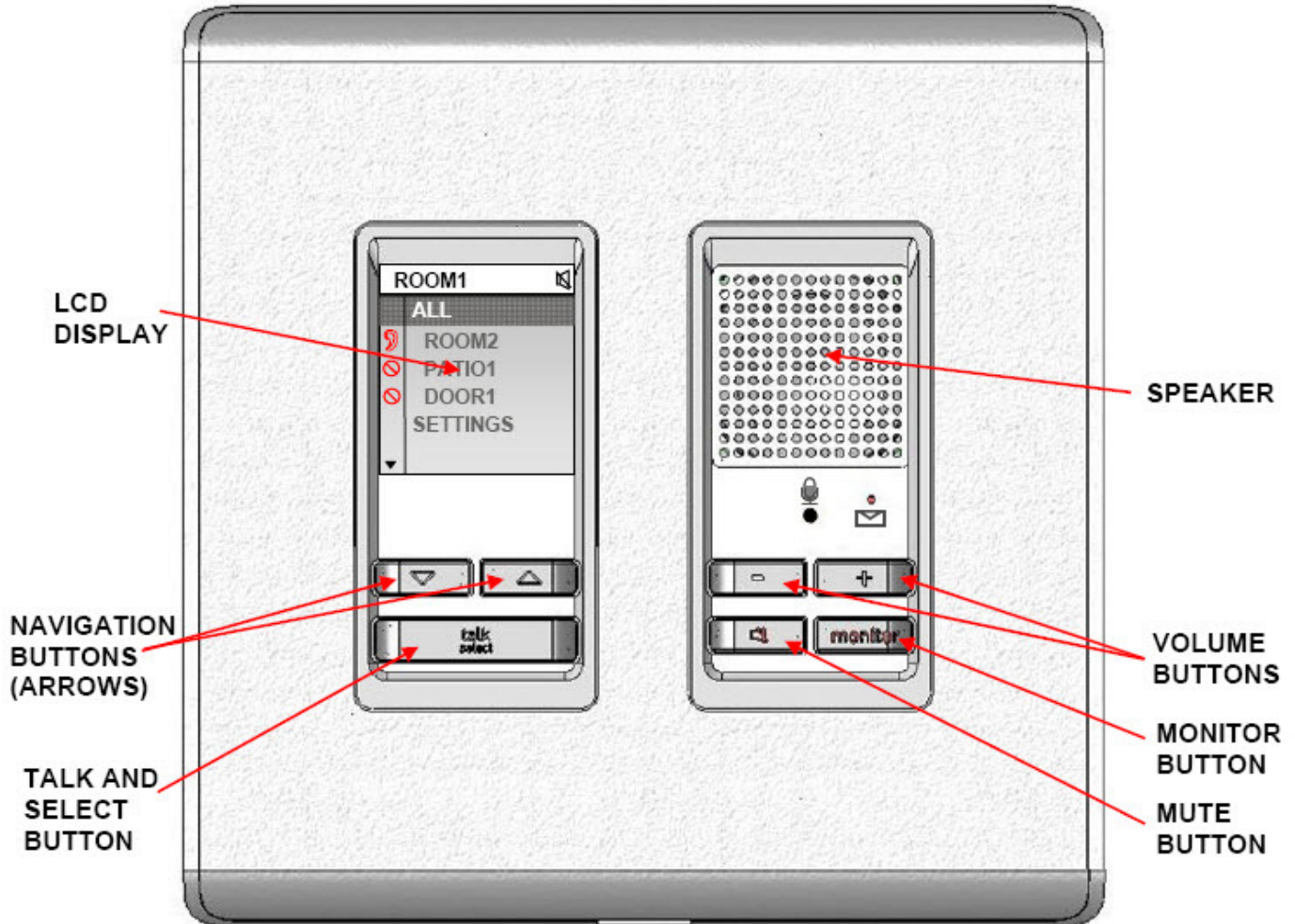

1. How to Navigate the User Interface:

Press Arrow Buttons to move highlight to selection:

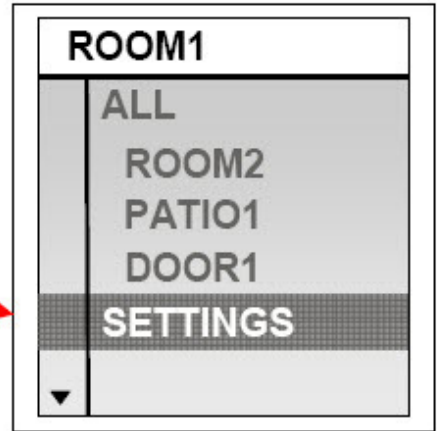

Press TALK/SELECT Button to see selection sub-menu:

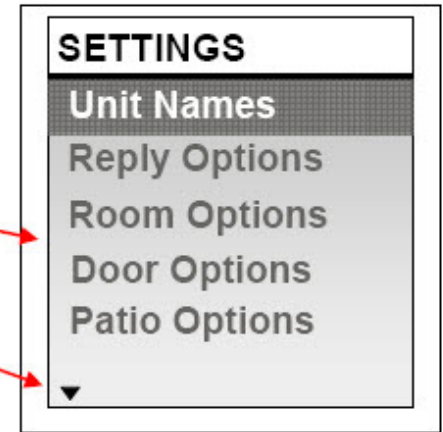

A down-arrow in the lower-left corner means there are more sub-menu items.

Press down-arrow to see all items:

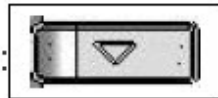

At the end of the sub-menu items, you will see BACK at the bottom of the screen.

Press the down-arrow button to highlight BACK and:

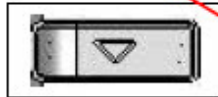

Press TALK/SELECT to move up one menu level (to the SETTINGS screen in this example).

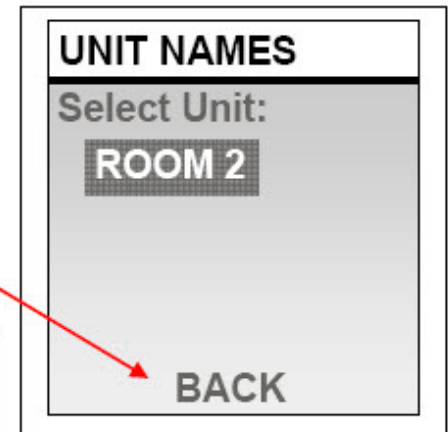

2. Pop-up Style Message Screens:

Press either Volume Control Button to see bar-graph style screen:

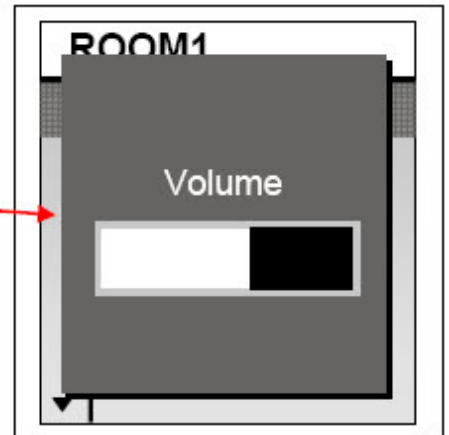

Use buttons to control volume:

Display changes back to normal after 2 seconds of inactivity.

Press MUTE Button to place Unit in MUTE Mode:



MUTE button is backlit red While Unit is in MUTE Mode.

Display changes back to normal after 2 seconds of inactivity.



Press MONITOR Button to place Unit in MONITOR Mode:



MONITOR button is backlit red While Unit is in MONITOR Mode.

Display changes back to normal after 2 seconds of inactivity.



D. System Operation

1. How to Page or "ALL" Call

The receiver of a Selective Call will hear a tone when the sender presses TALK/SELECT and then the sender talking to them.



The receiver of the Selective Call will see their display highlight the location of the sender.



When the sender releases the TALK/SELECT Button, a second tone is heard. Receiver now has 10 seconds (default) of hands-free reply time.



At the end of this hands-free time a third tone is heard to define the end of the call.

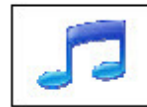

2. How to Reply to a Page

The receiver of a Page will hear a tone when the sender presses TALK/SELECT and then the sender talking to them.



The receiver of the Page will see their display highlight the location of the sender of the Page.

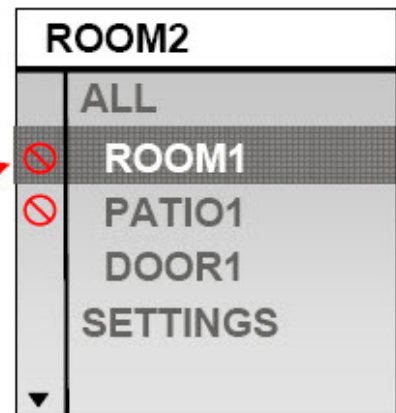

When the sender releases the TALK/SELECT Button, a second tone is heard. Receiver now has 10 seconds (default) of hands-free reply time.



At the end of this hands-free time a third tone is heard to define the end of the call.



The only way to exit a Page early, is to press the MUTE button:

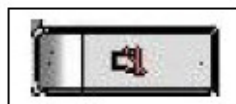

3. How to Selectively Call a Location

Press the arrow buttons to highlight the location you want to call.

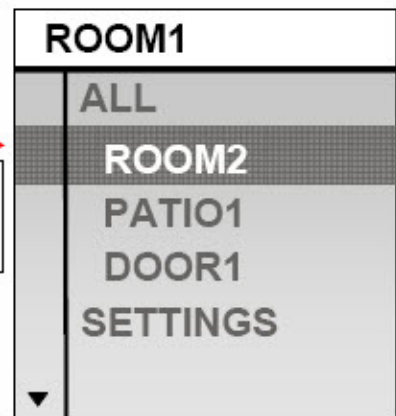
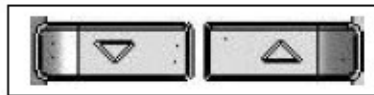

Press and hold the TALK/SELECT button and speak.



When you press the button, a tone will be heard at the receiving unit to tell them you are beginning to talk.



When you release the button, a second tone is heard at the receiving unit to let them know you have finished speaking and their 10 seconds (default) hands-free reply time has started.



At the end of this 10 second time, a third tone is heard at the receiving Unit to define the end of the call.



If the Unit you attempt to Selectively Call is in MUTE mode, the sender will see this screen for 2 seconds.

The display changes back to normal after the 2 second period.



If the unit you attempt to Selectively Call is involved in another conversation, the sender will see this screen for 2 seconds.

The display changes back to normal after the 2 second period.



A Patio Unit cannot initiate a Selective Call (No LCD screen to select receiver).

A Door Unit may be selectively called.

4. How to Reply to a Selective Call

The receiver of a Selective Call will hear a tone when the sender presses TALK/SELECT and then the sender talking to them.

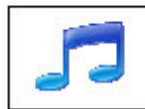

The receiver of the Selective Call will see their display highlight the location of the sender.

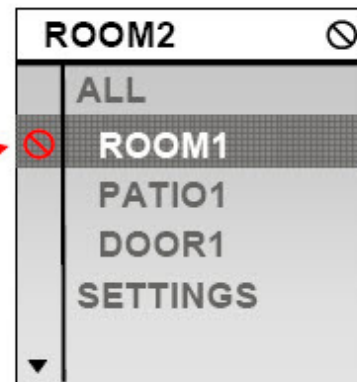

When the sender releases the TALK/SELECT Button, a second tone is heard. Receiver now has 10 seconds (default) of hands-free reply time.

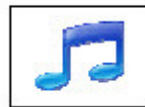

At the end of this hands-free time a third tone is heard to define the end of the call.



5. How to Mute a Unit

Press the MUTE button:



The MUTE button backlight changes from white to red.

The display changes for 2 seconds to show that no other Units can contact you.

The display changes back to normal after 2 seconds.

The Muted Unit cannot initiate Pages or Selective Calls.

MUTE may be disabled at a particular Unit through its Settings menu, Room Options. This is handy for a child's room where you wouldn't want the child to be able to Mute their room, and avoid contact.



6. How to place a Unit in Monitor Mode

Press the MONITOR button:



The MONITOR button backlight changes from white to red.

The display changes for 2 seconds to show that Monitor is ON. This means the microphone in the Unit is turned on and all other non-muted and non-monitored Units will hear an sounds occurring in the monitored room.



The display changes back to normal after 2 seconds.

The Monitored Unit will not receive Pages or hear Door Unit door tones, but can receive Selective Calls. This feature is handy for elder care where you can Hear a noise and selectively ask if everything is OK.

The Monitored Unit cannot initiate Pages or Selective Calls.

MONITOR may be disabled at a particular Unit through its Settings menu, Room Options. This is handy for a child's room where you wouldn't want the child to put their Unit in Monitor to avoid Page contact.

7. How to Temporarily Disable a Patio Unit

From any Room Unit, press the arrow buttons to highlight the SETTINGS selection.

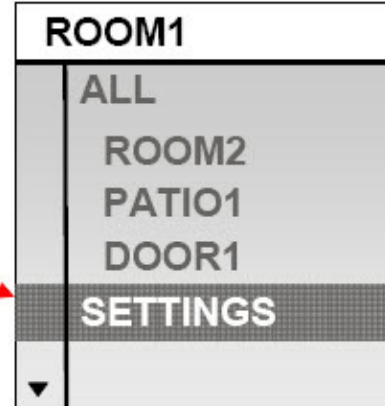

Press the TALK/SELECT button.



Press the arrow buttons to highlight Patio Options.

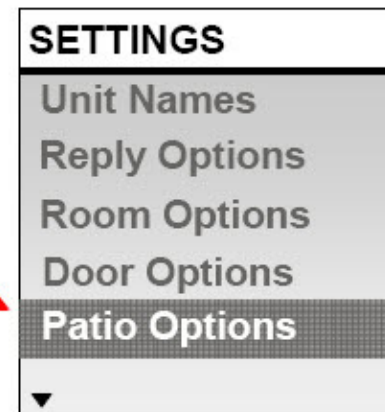

Press the TALK/SELECT button.



Press the arrow buttons to highlight the Patio Unit that you wish to disable.

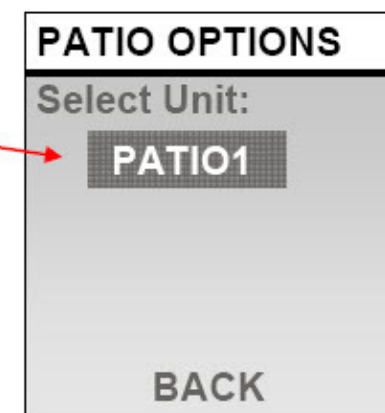

Press the TALK/SELECT button.



Press the arrow buttons to highlight the Status selection and press the TALK/SELECT button.

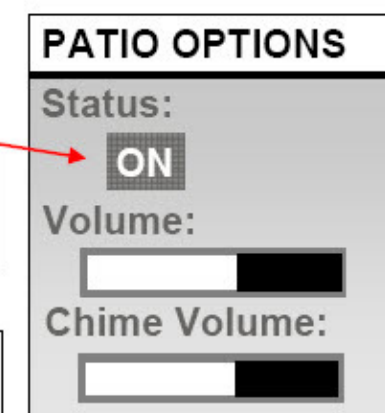

Use the arrow buttons to select OFF or ON.



This screen can also be used to control the default volume, chime volume, whether it can be reached by an All Call (Page), whether it can be placed in Monitor Mode and its default timeout before going into Sleep Mode.

NOTE: You will need to turn this **Patio Unit** back **ON** (following the same steps) before you can utilize it at a later time.

PATIO1
Chime Volume: 
All Call: YES
Monitor: NO
Time Out: 1 Min
BACK

8. How to initiate a Door Call

When a guest presses the Door Chime button on a Door Unit, all non-Muted non-Monitored Room Units that are not involved in another conversation will hear a door tone at their unit, and their unit will wake up if asleep and display a pop-up screen for 2 seconds to tell you that the Door Bell is ringing.



The display then goes back to normal with the Door Unit highlighted.

The Door Unit will be highlighted for 1 minute (default), during which time any non-busy Unit can initiate the Door Call by pressing and holding the TALK/SELECT button and speaking.

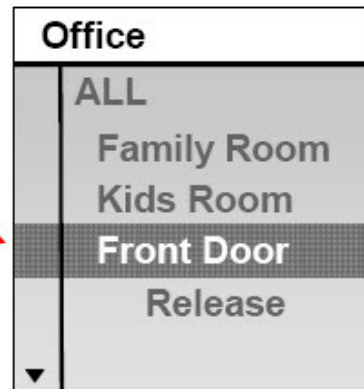

Patio Units can also initiate a Door Call directly by pressing and holding their Door button and speaking.



Beyond the default timeout, Room Units will need to use the arrow buttons to highlight the Door Unit before pressing and holding the TALK/SELECT button to speak.



When done talking to the guest at the Door Unit and the TALK/SELECT button (or Patio Door button) is released, a single tone will be heard at the Door Unit to let the guest know they can reply.



The guest has a 10 second hands-free reply time after the first tone is heard. At the end of that time, a different tone is heard at each unit to let them know that the hands-free reply time is over.

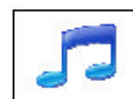

9. How to initiate a Door Release

If an electronic door release has been installed and enabled, the label "Release" appears below the Door label.

To initiate a door release, use the Arrow buttons to highlight "Release"

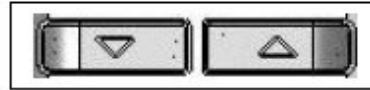

and

press the TALK/SELECT button.



All other Room Units will display a message that the Door is being Released

and

an audible tone will be generated.

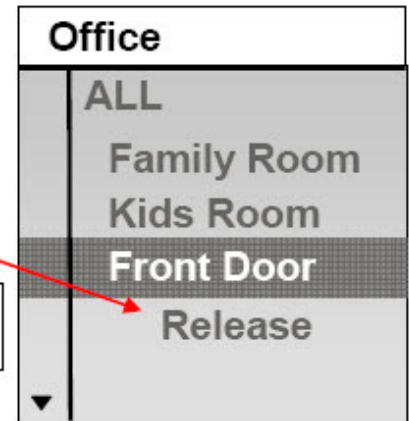

10. How to select a Door Chime Tone

One of 20 different Door Tones may be associated with any Door Unit's Door Chime button.

From any Room Unit, use the arrow buttons to highlight the Settings function and then press the TALK/SELECT button.

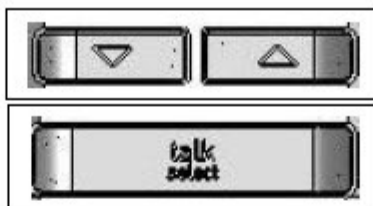

From the Settings screen, use the arrow buttons to highlight Door Options and press the TALK/SELECT button.

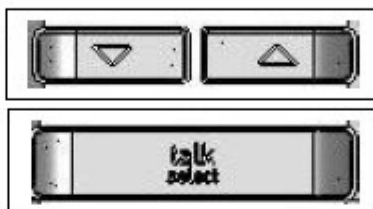

From the Door Options screen, use the arrow buttons to select the Door Unit you would like to associate a tone with and press the TALK/SELECT button. The Door Unit name will flash. Press the TALK/SELECT button again to move to the next screen.

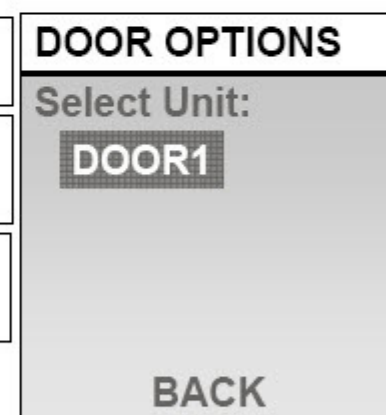
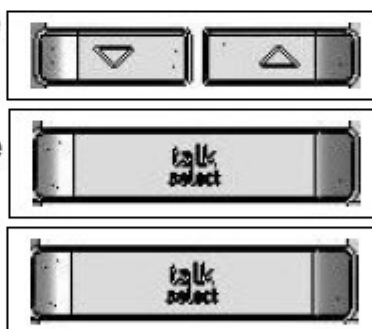

Use the arrow buttons to select the Chime option and press the TALK/SELECT button. The Chime selection will flash. Use the arrow buttons to select the Door Tone # that you would like to use with that Door Unit (each will play as you select them) and press the TALK/SELECT button to lock in the Chime#. See **Table 1** for a complete list of Door Tones.

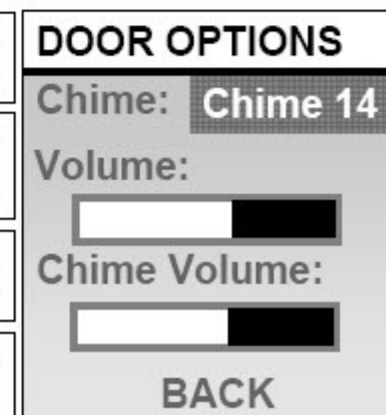
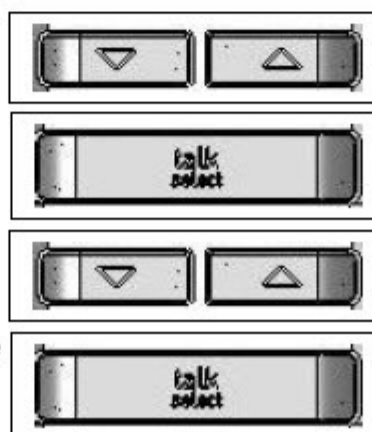

Door Tone Chime List

#	Door Tone Name	Type
1	On-Q Sound	Chime
2	On-Q Sound Alternate	Chime
3	Westminster Long	Chime
4	Westminster Short	Chime
5	Two Note (Ding Dong)	Chime
6	Two Note (Dong Ding)	Chime
7	Jetson's Doorbell	Chime
8	Eastern Strings	Ethnic
9	Calypso Party	Ethnic
10	Für Elise	Classical
11	Beethoven's 5 th	Classical
12	Happy Birthday	Celebration
13	Pomp & Circumstance	Celebration
14	Wolf Howl	Holiday
15	Jingle Bells	Holiday
16	We Wish You a Merry Christmas	Holiday
17	Auld Lang Syne	Holiday
18	Oh Canada	Patriotic
19	America the Beautiful	Patriotic
20	On-Q Sound + Dog	Security

Table 1

E. System Personalization

The following section explains how to use any Selective Call Room Unit to personalize both global options and local settings of the Selective Call System using the Settings selection from the Room Unit Main Menu.



1. Choosing Unit Names

From any Room Unit in the house, use the arrow buttons to highlight SETTINGS and press TALK/SELECT.

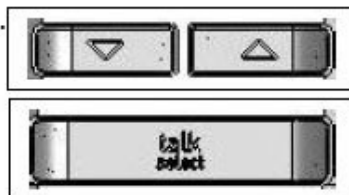

From the SETTINGS screen, use the arrow buttons to highlight Unit Names and press TALK/SELECT.

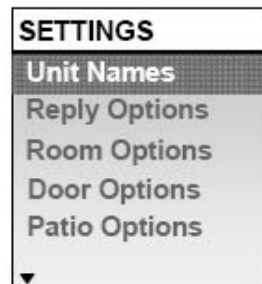
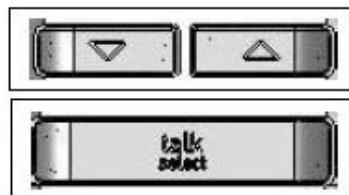

The UNIT NAMES screen will have your current Unit Name highlighted.

Press TALK/SELECT to select it (it will flash and begin beeping at full volume so that it is audible from most places within the home) or use the arrow keys to select another location.

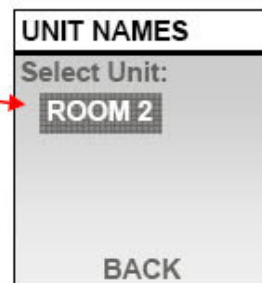

Press TALK/SELECT and the screen will show your "old" Unit Name with a New Unit Name area highlighted.



Press TALK/SELECT again and use the arrow buttons to select a New Unit Name from the list in **Table 2** for Rooms or Patios and **Table 3** for Doors or Patios.



When you have decided on a New Unit Name, press TALK/SELECT to lock in that Name. The New Unit Name shown now becomes that Unit's name and all other Room Units interfaces are populated with the Unit's New Name.



UNIT NAMES
Old Name: ROOM 2
New Name: Master Suite
BACK

Attic	Dock	Kid's Room	Office 4
Baby's Room	Entertain. Rm	Kids Room 2	Office 5
Balcony	Family Room	Kids Room 3	Office 6
Bar	Foyer	Kids Room 4	Office 7
Basement	Front Desk	Kitchen	Office 8
Bath 1	Game Room	Laundry Room	Owner's Suite
Bath 2	Garage	Laundry Rm 2	Parlor
Bath 3	Gathering Rm	Library	Patio
Bedroom 1	Grandma's Rm	Living Room	Play Room
Bedroom 2	Grandpa's Rm	Lunch Room	Pool
Bedroom 3	Great Room	Main Office	Porch
Bedroom 4	Guest House	Master Bath	Powder Room
Bonus Room	Guest Bath	Master Closet	Reading Room
Break Room	Guest Room	Master Deck	Rec Room
Breakfast Rm	Guest Suite	Master Suite	Sitting Area
Casita	Hallway 2	Media Room	Study
Closet	Hallway	Mom's Room	Sun Room
Computer Rm	Hobby Room	Mud Room	Utility Room
Dad's Room	Home Office	Nook	Veranda
Deck	Home Office 2	Office	Waiting Room
Den	Home Theater	Office 2	Wine Cellar
Dining Room	In-Law Suite	Office 3	Workshop

Table 2

Back Door	Casita	Front Gate	Patio
Back Gate	Deck	Front Porch	Porch
Balcony	Dock	Garage	Side Door
Balcony 2	Front Door	Guest House	Veranda
Basement Door	Front Entry	Master Deck	

Table 3

2. Modifying Hands-Free Reply Time

This is a global option which affects all Room and Patio Units. It determines the amount of time a receiving unit remains in hands free reply mode.

From any Room Unit in the home, Use the arrow buttons to highlight SETTINGS and press the TALK/SELECT button.

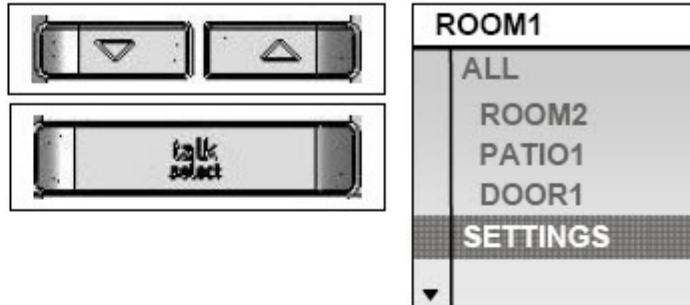

Use the arrow buttons to highlight Reply Options and press the TALK/SELECT button.

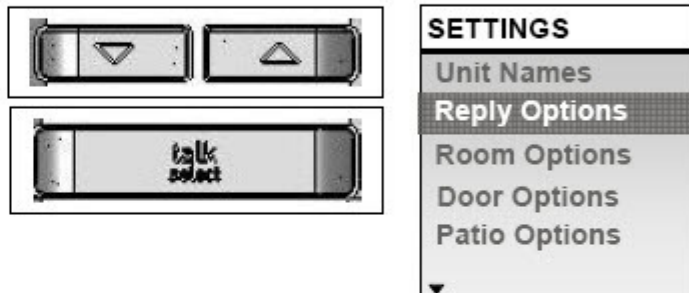

The current Hands-Free Reply Time will be highlighted.

Press TALK/SELECT and the current setting will flash. Use the arrow buttons to make a new selection.

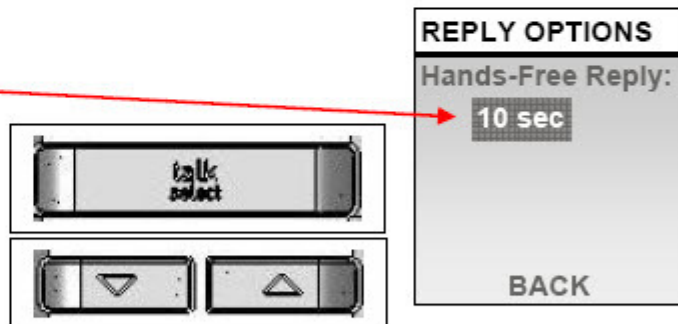

The options are 60 seconds, 30 seconds, 15 seconds, 10 seconds (the default), 5 seconds, or disabled.

Press TALK/SELECT to lock in that new global selection.



Door Reply times are separately configured under Installer Setup.

3. Room Options (Local Settings)

These options must be configured from the Room Unit in which the option is to be applied.

Use the arrow buttons to highlight SETTINGS and press the TALK/SELECT button.

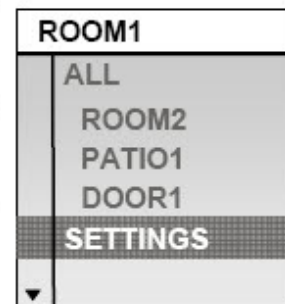
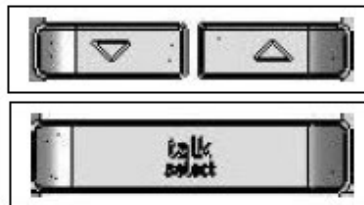

Use the arrow buttons to highlight Room Options and press the TALK/SELECT button.

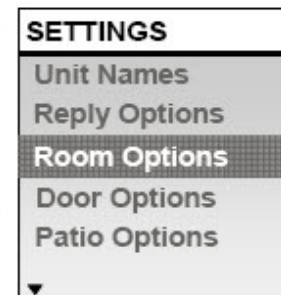
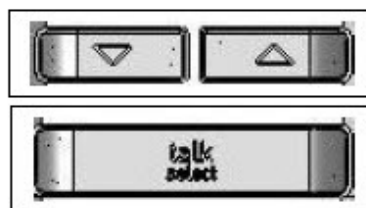

Use the arrow buttons to highlight a selection and press the TALK/SELECT button. The selection flashes and the arrow buttons are used to make a new selection. When you have decided on a new selection, press TALK/SELECT to lock in the new selection.

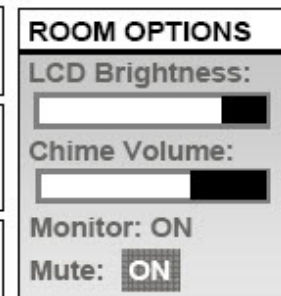

The first setting “LCD Brightness:” determines how bright or dim that Room Unit operates.

“Chime Volume:” determines how loud or soft the door chime will play when someone pushes a Door Unit button.



“Monitor” and “Mute” can be turned ON or OFF, meaning those button functions may be disabled or enabled at that particular Room Unit.

You can also determine the period of time of inactivity (1 minute-default, 5 minutes or 10 minutes) before a Room Unit goes into sleep mode (Timeout).

The “Sort” option determines whether you want the list of Units displayed on that Room Unit alphanumerically (Alpha), or by usage. Dynamic, (the default) displays the list with the most used Units at the top of their section of the display.

The Theme option allows you to select one of four different color pallets for that particular Room Unit's display.

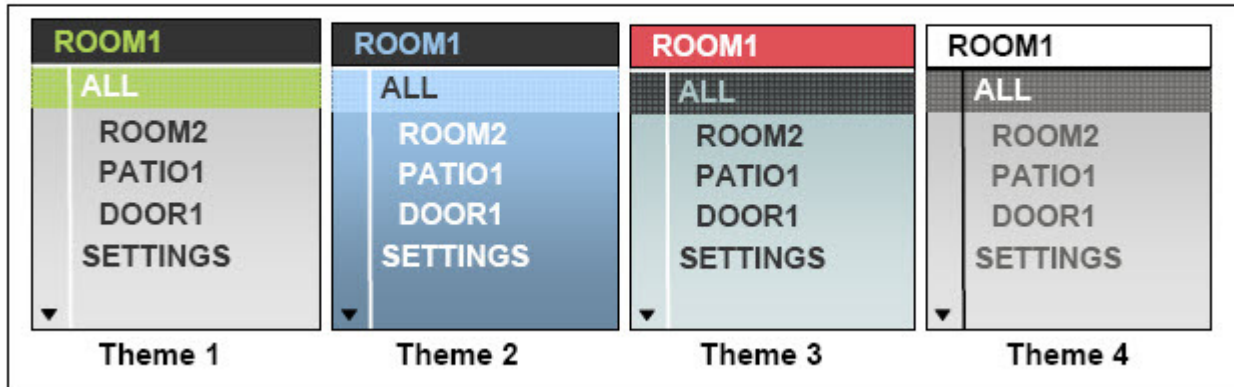

ROOM

4. Door Options (Local Settings)

The Door Options are specific only to the selected Door Unit.

Use the arrow buttons to highlight SETTINGS and press the TALK/SELECT button.

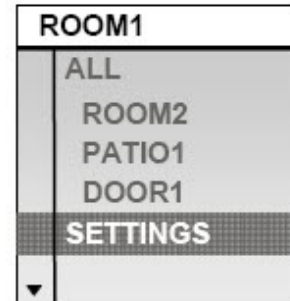

Use the arrow buttons to highlight Door Options and press the TALK/SELECT button.

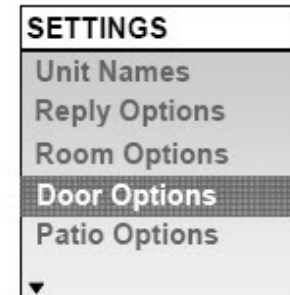
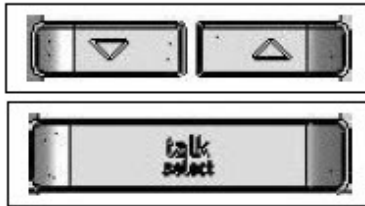

Use the arrow buttons to highlight the Door Unit selection and press the TALK/SELECT button. The selection flashes.

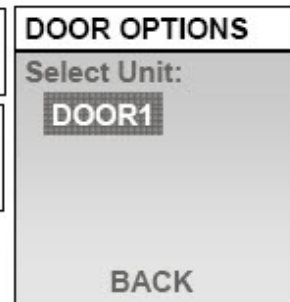
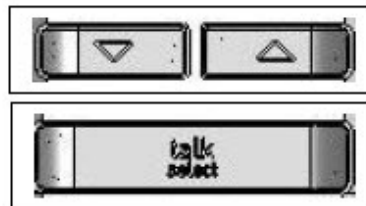

Press TALK/SELECT again to see the available options.



Use the arrow buttons to highlight a selection and press the TALK/SELECT button. The selection Flashes.

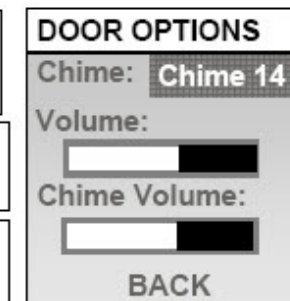
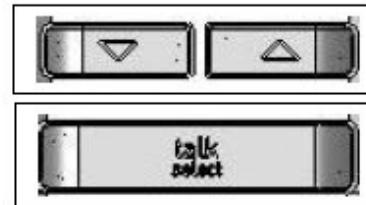

Use the arrow buttons to make a new selection.
When you have decided on a new selection, press TALK/SELECT to lock in the new selection.

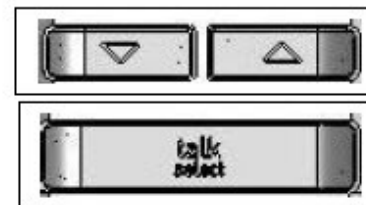

The first setting "**Chime:**" determines which of the 20 optional door tones will be associated with the door button on that particular Door Unit (see **Table 1** for a complete Door Chime Tone list).

The **Volume** and **Chime Volume** options allow you to set the default volume levels for that particular Door Unit.

5. Patio Options (Local Settings)

The Patio Options are specific only to the selected Patio Unit.

Use the arrow buttons to highlight SETTINGS and press the TALK/SELECT button.

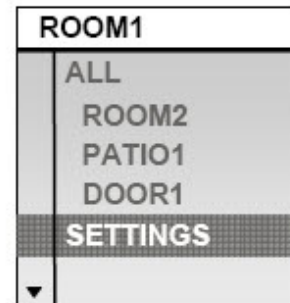
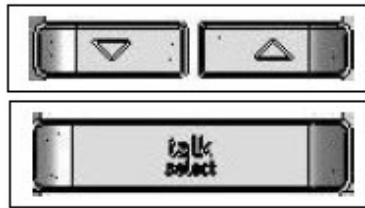

Use the arrow buttons to highlight Patio Options and press the TALK/SELECT button.

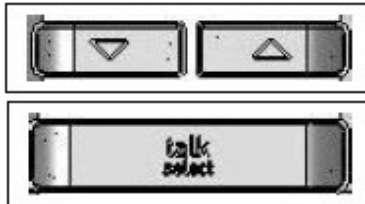

Use the arrow buttons to highlight the Patio Unit selection and press the TALK/SELECT button. The selection flashes.

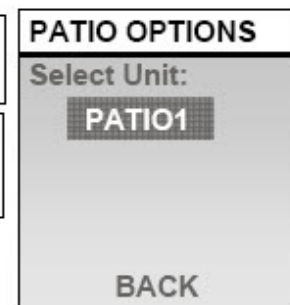
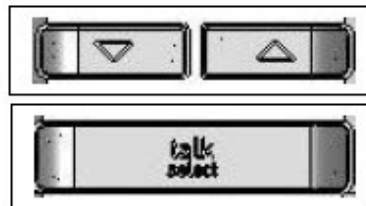

Press TALK/SELECT again to see the available options.



Use the arrow buttons to highlight a selection and press the TALK/SELECT button. The selection flashes.

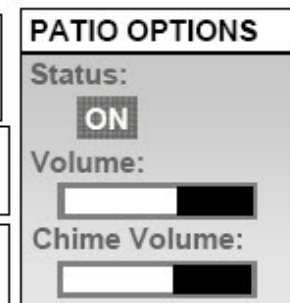
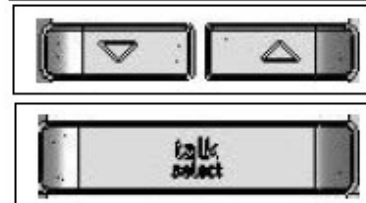

Use the arrow buttons to make a new selection. When you have decided on a new selection, press TALK/SELECT to lock in the new selection.

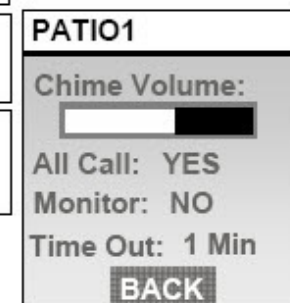
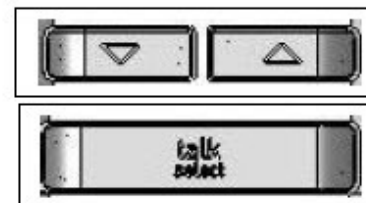

The first setting “**Status:**” determines whether that Patio Unit is enabled (ON) or disabled (OFF). This is a handy feature for disabling the Patio Unit at night or while you are away.

The "**Volume:**" option determines the default volume level at that particular Patio Unit.

The "**Chime Volume:**" option determines the default volume level of Door Chimes played at that particular Patio Unit when someone pushes the doorbell button on a Door Unit.

The "**All Call:**" option enables (YES) or disables (NO) the broadcast Page ability from that Patio Unit.

The "**Monitor:**" option enables (YES) or disables (NO) the Monitor button on that particular Patio Unit.

The "**Time Out:**" option is used to determine how quickly the Patio Unit button backlights goes to sleep after inactivity (1 minute – default, 5 minutes, or 10 minutes).